

MAKE THIS BENDING BRAKE

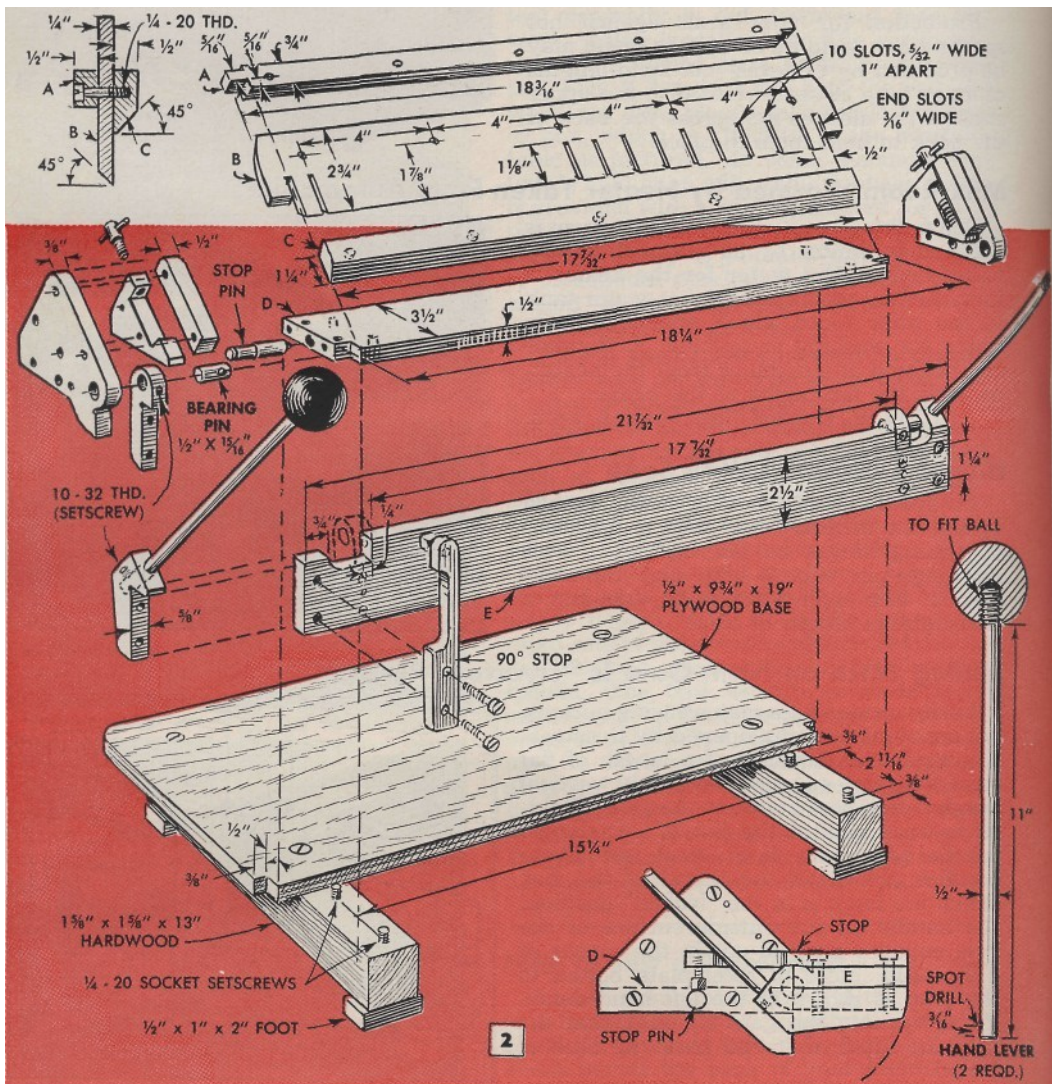

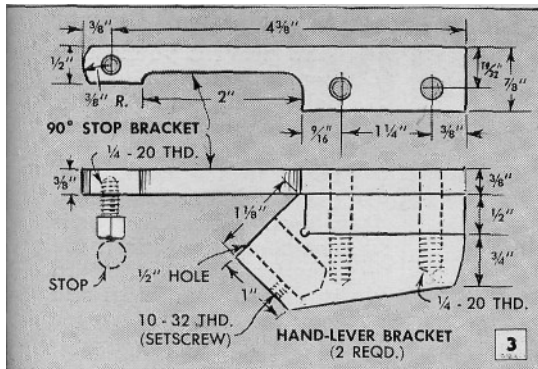

FOR YOUR SHOP

By Fred C. Iglehart

THIS BRAKE is small-shop size, makes those clean, sharp bends in sheet metal that will delight the eye of a craftsman who has had to improvise methods of bending. It takes light sheet metals up to 17 in. wide. The hold-down blade moves at an angle of 45 deg. to the bed and adjusts automatically to the thickness of the materials to be bent. The blade is slotted to provide the clearances necessary to permit raising, in successive steps, 1/2-in. flanges on the four sides of the work, as in forming a box or tray, radio chassis, motor base, or similar work. A retractable stop at the 90-deg. position permits the operator to make repetitive right-angle bends. The throat opens to 5/16 in. to admit flanged parts.

All main parts except the table, or base, are made from cold-rolled stock. These include the parts detailed in Figs. 1 and 3 and parts A to E inclusive in Fig. 2. Note that parts A, B and C are shown assembled in the upper left-hand sectional view in Fig. 2. See also Figs. 4 and 5. Stock 3/8 and 1/2 in. in thickness is used for the right and left end plates and the hold-down supports and guides. The bending-bar brackets also are of 1/2-in. stock. Note in the right-hand detail, Fig. 2, showing end plate and hold-down support assembled, that the right end plate is a duplicate of the left plate with the exception of the lug formed on the lower edge of the latter. Note also that screw holes are counterbored to take socket-head screws flush. The hole pattern for 5/32-in. steel dowels is not dimensioned; only the approximate positions are shown. Where a lathe is not available use a straight 3/8-in. rod for the stop and substitute 5/16-in. cap-screws for the spring-tensioning screws. This will simplify construction without affecting operation of the brake.

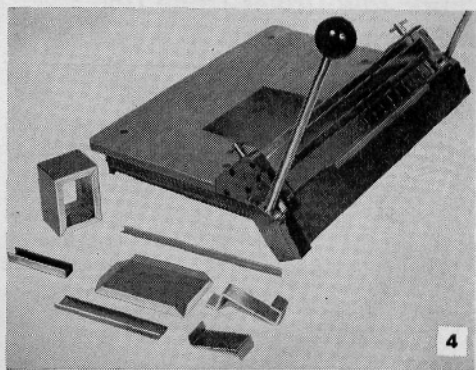

Above, brake and examples of flanged work done in light sheet metals. Below, brake assembly with left end plate, handle and 90-deg. stop removed to show hold-down support and spring-tension device

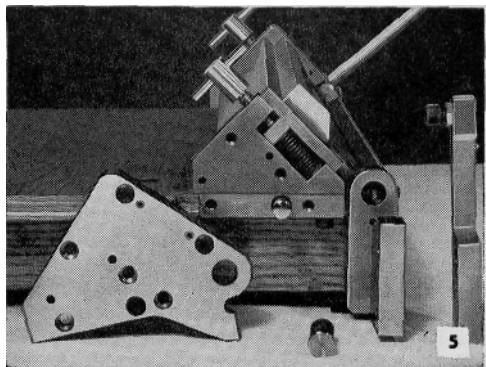

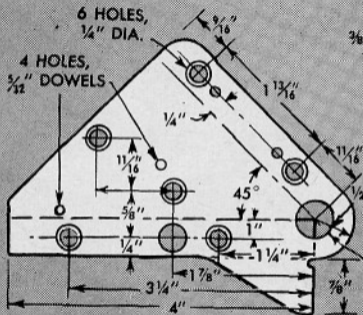

LEFT END PLATE

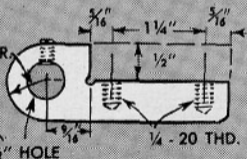

BENDING-BAR BRACKET
(2 REQD.)

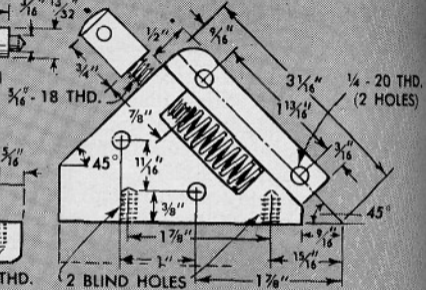

LEFT HOLD-DOWN SUPPORT

