



By Manley Mills

the original machine at a total cost of less than \$150. This included a number of items that were bought new, such as the 2 1/2 hp Briggs & Stratton engine, tires, countershaft bearings, pulleys and some of the raw metal stock. Naturally, this figure can be reduced by using second-hand materials on a larger scale.

ALTHOUGH this little tractor may be a midget in size, it's a giant in performance. With plenty of power to do all the light hauling and towing jobs around the home or farm, it takes all the hard work out of these chores. In fact, you're going to have a problem trying to reserve that right for yourself. There's something fascinating about the little tractor at work, and everybody wants to get into the act. In addition to its usefulness for lawn and yard work, it could be employed in small plants, warehouses or airports for light towing jobs.

Although frequently mistaken for a factory-built machine, the tractor is built, entirely from materials that are cheaply and easily obtainable in most localities. Construction follows conventional practice and requires only hand tools for the greater part of the job. If you aren't equipped or qualified to do certain phases of the work, like the welding, you can have those things done at your local machine shop or garage.

John F. Mills, automotive technician of Marietta, Georgia, designed and built

In a test to determine its drawbar capacity, the tractor was hitched to a full-size automobile on a level asphalt street. It was a hot day, and the asphalt had just enough stickiness to prevent

The 36-in. high tractor has a speed of 8 mph, weighs 190 lbs; 2 1/2 hp engine provides power.

Pronounced camber of front wheels reduces deflecting action caused by small stones.

Rear view shows the Cushman chain and drive sprockets attached to the two countershafts.



No need to burden yourself with heavy work when you can build this multi-purpose tractor for under \$150.

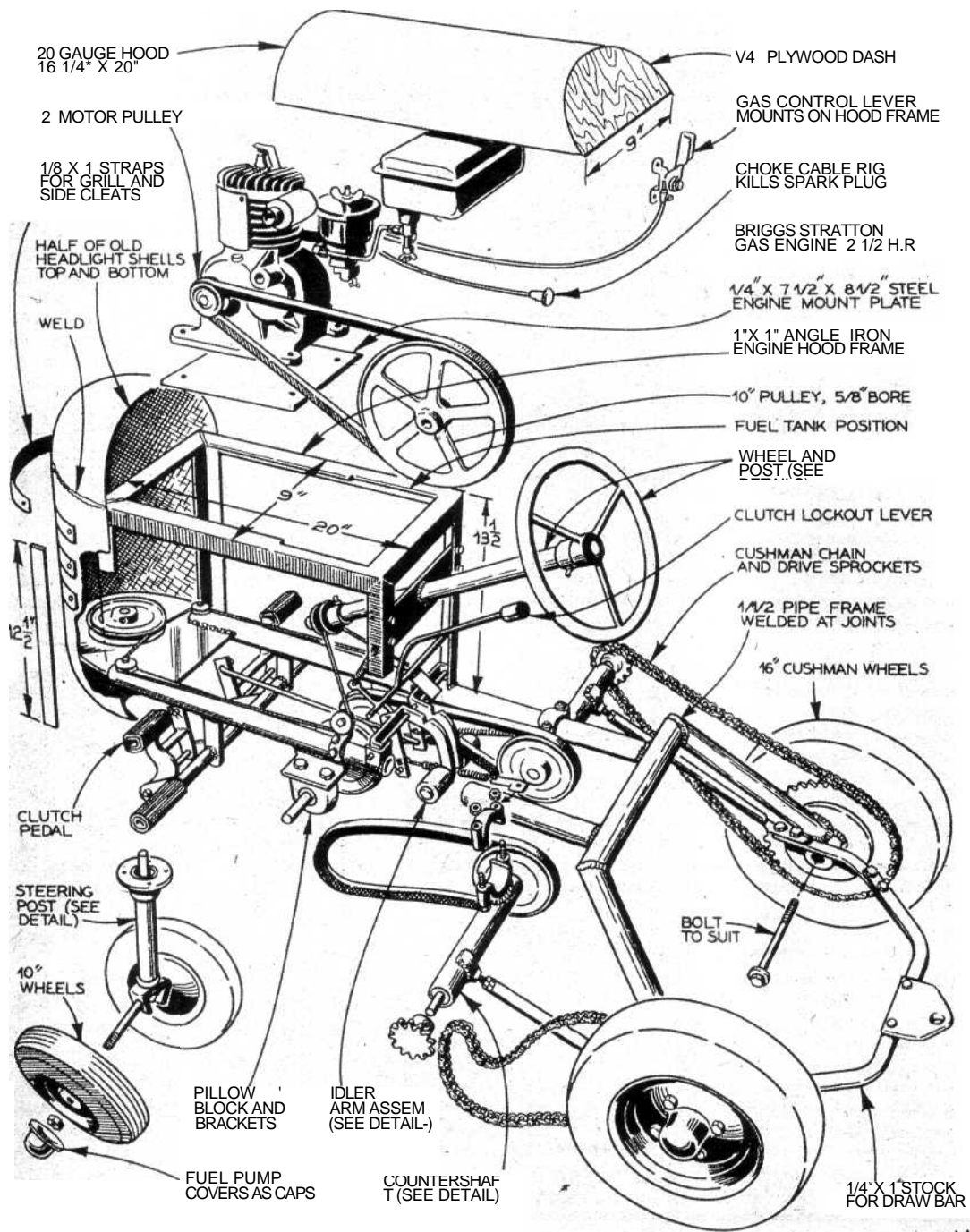

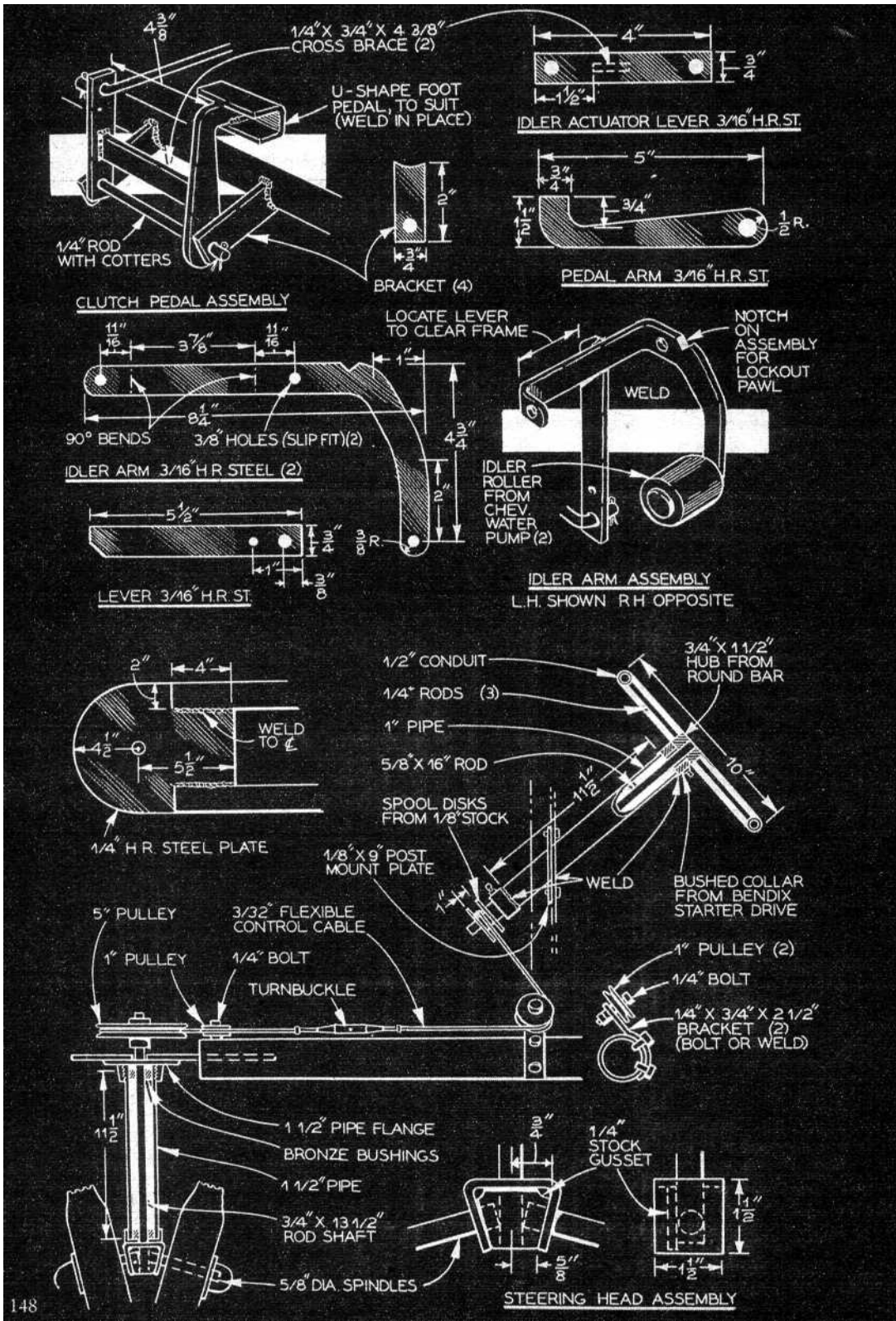

wheel-spin, so no trouble was experienced in starting and pulling the load. With its present gearing the tractor has a maximum speed of about 8 miles an hour; it weighs 190 pounds. A greater reduction, which might be desirable for certain jobs, can be had by changing the sizes of the countershaft pulleys.

The rear wheels have an overall diameter of 16 inches, will turn at 21 rpm. The ratio between the engine and forward countershaft is 5:1 (2 in. and 10 in. pulleys); rear countershaft to wheels is 4.5:1 (standard Cushman sprockets). With countershaft pulleys of equal size for front and rear, the total gear ratio is 22.5:1, which means that at an engine speed of 3800 rpm, the road speed is 8 miles an hour. With 3 in. pulleys on the forward countershaft and 5 in. ones on the rear, or sprocket shafts, the ratio is 37.35:1, which at maximum rpm would give a speed of a little under 5 miles an hour.

Dimensions not specified in the plans are left to your own judgment. Some may have to be altered to suit materials you may have available. Generally speaking, however, it's best to stick to the basic dimensions given.

Construction starts with the frame. Angle iron could be used in place of tubing for the side rails if it happens to be more easily obtainable, but the tubular type is better looking and stronger. The original rear wheel struts were spare-wheel brackets from a 1931 Cadillac. They needed practically no re-work other than welding them together to form an assembly something like a Cessna-type airplane, landing gear. Since these parts are not too plentiful, an alternate method of construction is illustrated in the plans. But, if you're lucky enough to find a pair of these brackets, a lot of your work is already done for you.

The problem of a differential was solved in a simple but effective manner, without the use of gears, by driving the wheels through independent belt-driven countershafts controlled by a pedal-operated idler. Thus, the power to either wheel can be disengaged without affecting the other. When a sharp turn is made, the inside wheel is disengaged

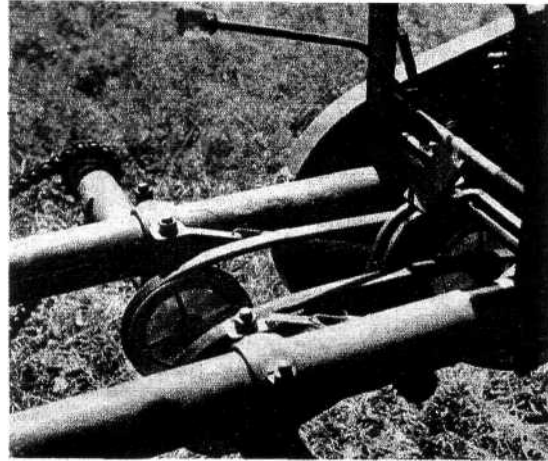

The two belts ride on four 4-in. dia. pulleys. Note clutch spring attached to frame.

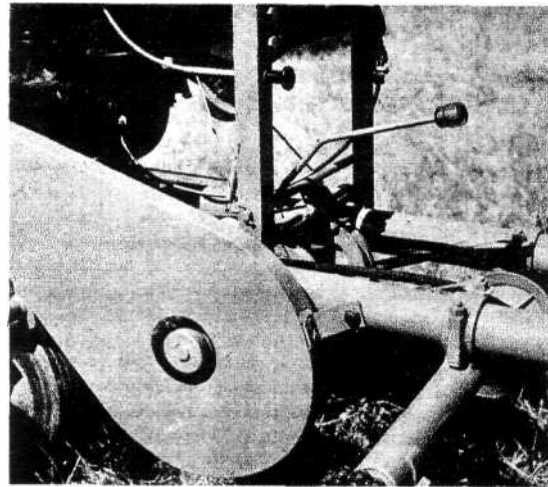

Engine drive belt and pulleys are covered by metal guard, located on left-hand side.

Detail below shows foot rest and clutch pedal; both are covered by rubber hose.

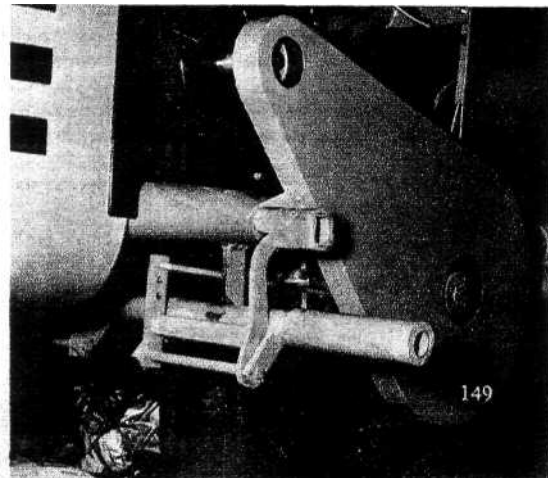

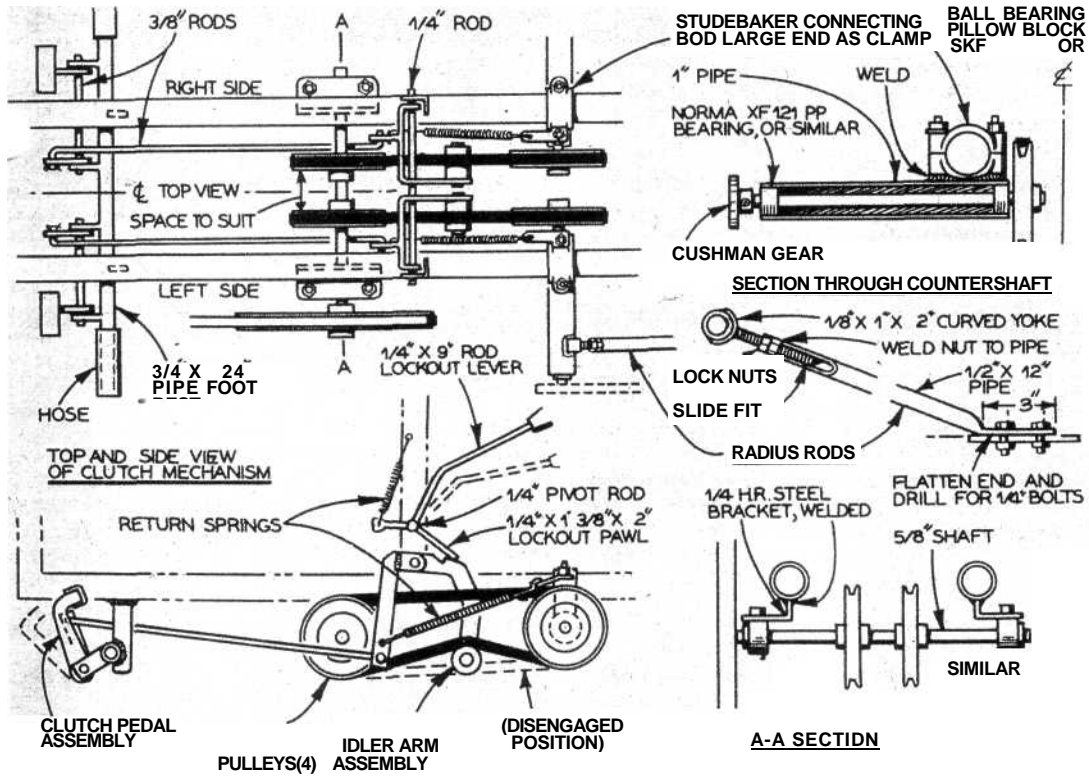

to prevent slippage, and all the power goes to the outside wheel. Relative to this operation, an odd fact was discovered during test runs of the tractor. Only in the sharpest turns do the clutches have to be manually operated. During normal maneuvering the action is automatic; the belt on the inside of a curve will slacken visibly, then tighten up again when you straighten out. Manual operation of the clutches is a natural, almost instinctive action, and has its parallel in the handling of a big tractor when you apply the individual brakes to facilitate turning. As illustrated in the plans, the device that locks the transmission in neutral, necessary for starting the engine, operates only when you depress both pedals simultaneously. To make a smooth start just hold the clutch pedals down while you release the lock with the lever, then hold the lever up until power is engaged by easing back on the pedals.

Simple wooden jigs can be improvised to hold parts in position for welding. [Continued on page 190]

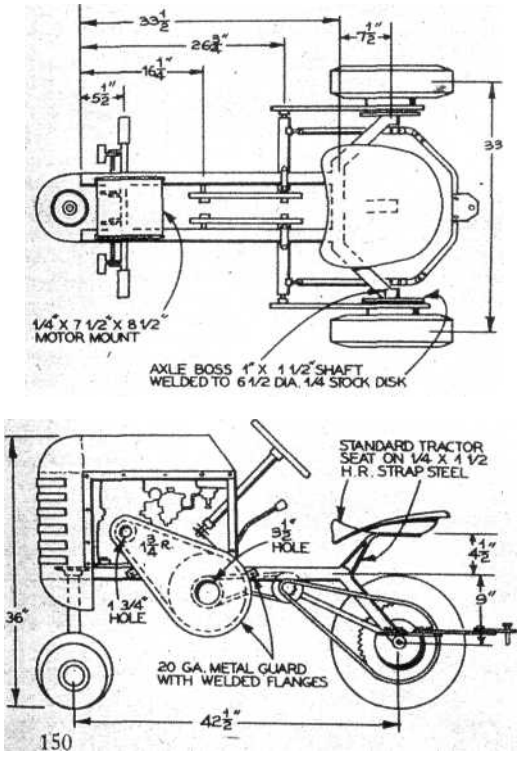

Midget Tractor

[Continued from page 150]

Correct alignment is most important in the installation of the countershafts and other parts of the transmission system, both for the sake of smooth operation and prevention of excessive wear to the belts, chains and sprockets.

The cable-operated steering gear is adequate, yet simple, easy to adjust, and permits the steering post to be installed at a convenient angle, rather than horizontally along the top of the engine as on most small tractors. A wheel from an outboard motorboat steering gear or a similar wheel of suitable diameter can be used if you don't care to build one up yourself. Shortly after the photographs were taken, the steering ratio was increased by removing the pulley on the steering post and winding the cable on the shaft itself, adding circular flanges to retain the cable. This change is covered in the plans. With the original arrangement, it was felt that the response was a little too quick for comfortable handling.

The countershafts, as well as the engine, can be shifted to regulate belt or chain tension by providing elongated mounting holes. The rear countershafts can be moved back and forth along the side rails, clamped in position, and radius rods adjusted accordingly.

In setting up the drive system, you should start with the chains and work forward. Adjust them so that a slight pressure will show about 1/2 in. of slack at a point midway the front and rear sprockets. Because the slack in the countershaft belts will be taken up by the spring-loaded idler rollers, the setting of the front countershaft isn't so critical as long as the slack isn't excessive. You'll be just about right if you'll locate this shaft as specified in the plans. Finally, locate the engine so that the primary belt will "give" about 1/2 in. at its midpoint.

If the tractor is to be used under extremely dusty conditions, the chains will give longer service if they are enclosed in sheet metal guards. With reasonable care there is little danger of getting your clothing caught in the chains and sprockets. However, abbreviated guards might be installed over the countershaft sprockets.

In the original design no brakes are

provided since the engine compression acts very effectively. But, it is a fairly easy matter to rig brakes, either on the rear wheels or on the rear countershafts, and operate them from the same pedals that work the clutches. With such an arrangement, de-clutching and braking could be performed in one operation.

For a better riding comfort, if you're going to drive for long periods, a spring mount for the seat should be incorporated. However, the simple rigid mount as illustrated is comfortable enough for average use. The standard fuel tank supplied with small engines of the type we're using holds enough fuel for more than two hours, but there's room under the hood for a larger tank if you want to increase the range of operation.

The pronounced camber of the front wheels, as shown in the photos, is to minimize the deflecting action of small stones and irregularities of the ground. A single fork-mouthed front wheel could be installed. Using two wheels gives a better ride over the soft spots, due to greater ground contact area.

The name-plate, made from commercial Decal letters, adds a professional touch. Put a coat of clear varnish over the letters for protection against peeling. On the right-hand rear vertical member of the hood frame is the hand throttle control for regulating the governor to the desired operating speed. A commercial product, this item is easy to install. On the left-hand side opposite the throttle is a kill-switch for stopping the engine. It was made from an automobile manual choke control and pulls a piece of spring steel against the spark plug, shorting it out.

The rope-starter pulley is situated so that the engine can be started from the driver's seat. Rope-type starters with an automatic return are now available for most engines. With one of these gadgets, you don't have to wind up the rope for a start, or have to be careful not to lose it.

Finally, a few words of caution. Don't let the small size of this machine fool you into treating it as a toy. For the sake of safety, handle it with exactly the same respect and caution you give a big tractor. •