

Mulchmaker for gardening buffs

By MANLY BANISTER

ANY GARDENING BUFF knows the best way to fertilize the garden is with organic material and that the cheapest organic material is home-grown compost. Mulches for the garden also come dearly and you're tossing out valuable humus by setting out your clippings at the curb.

Now you can build this mulchmaker to help turn grass clippings, leaves and non-seed-bearing weeds into valuable compost or mulch. What the machine will do for you is shred the material, permitting a more thorough mixing of compost activators with the refuse, speeding its decay into compost, and making compost or mulch easier to shovel and spread.

You can make this mulchmaker from a 16-in. hand lawnmower and a 3-hp gasoline engine or a 1 to 1-1/2-hp electric motor. The first job is to strip the lawnmower of its handle, wheels and roller. Remove and discard the gears on the reel shaft. Follow the dimensions shown in the

The most inexpensive fertilizer is home-grown. The most inexpensive way to distribute it is with this mulchmaker that you can quickly make yourself

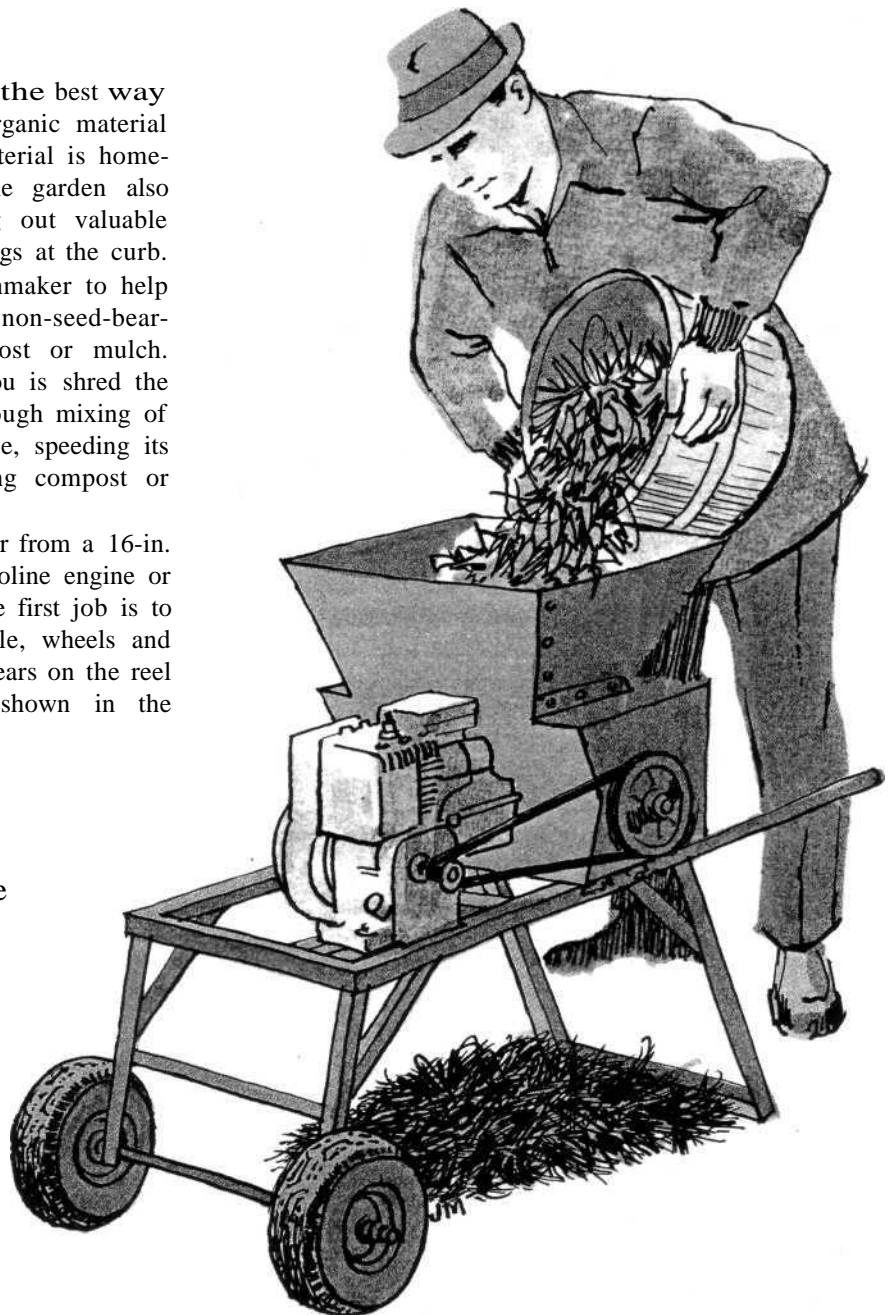

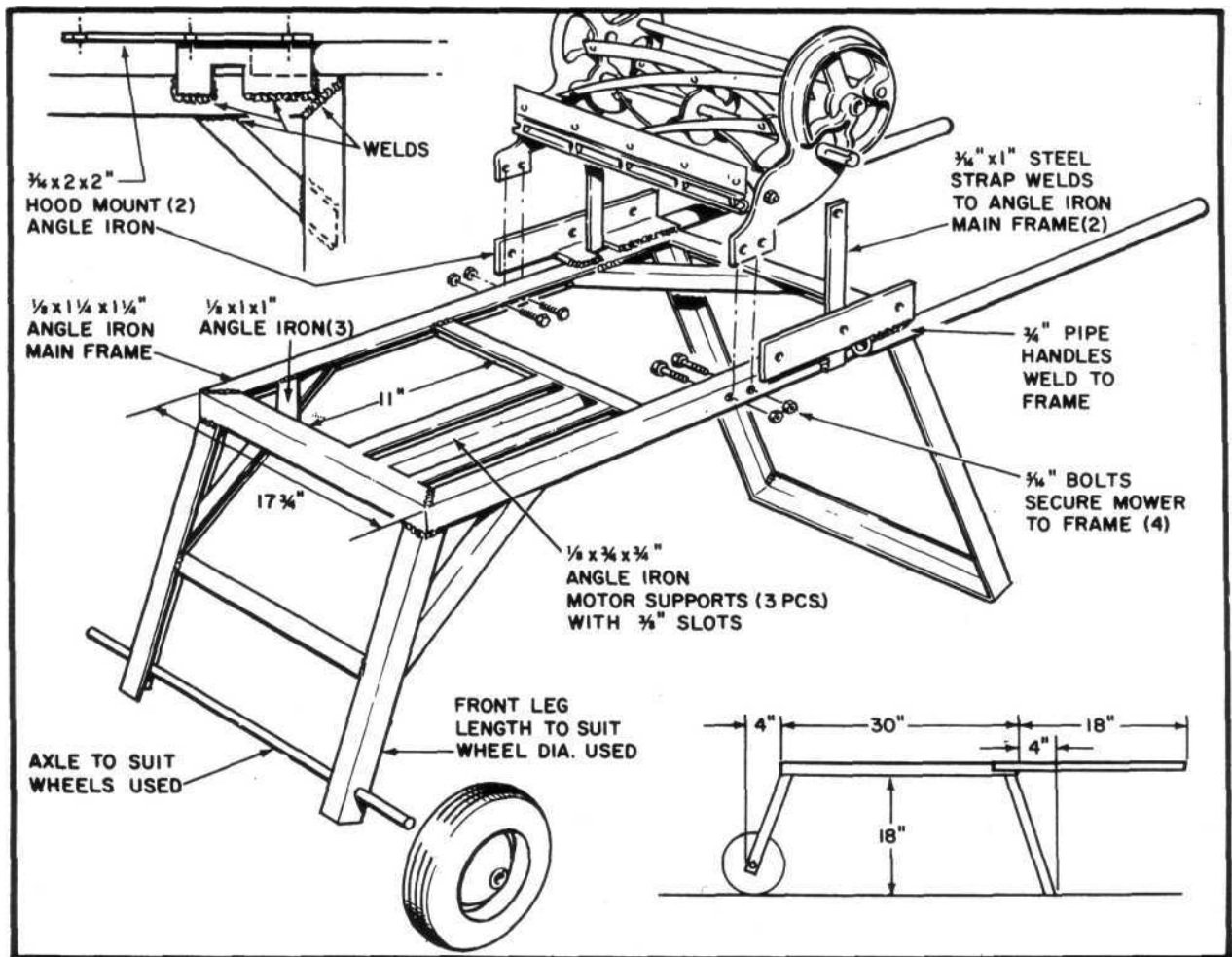

illustrations here if a 16-in. mower is used. The width would have to be varied for any other size mower.

Cut mitered notches at the corners of the angle irons to be used for the carriage frame and cut the other pieces to length. Bend the mitered areas into sharp corners and clamp to a welding table or to scrap plywood insulated from the table you're working on. This will prevent warping of the frame from the welding heat. Clamp the other pieces of the leg assemblies, corner braces, motor mount, mower supports, hood lugs and the pipe handles and weld them. All welds are made on the underside of the frame.

The length of the legs and the height of the carriage depend on the diameter of the wheels used. You can use the wheels from the mower, but they'll require a large axle. I bought 10-in. rubber-tired wheels, cut the legs to suit and mounted them on a 1/2-in. axle.

Drill and bolt the mower to the frame through the back roller mounts with 5/16-in. bolts. Then bolt the mower-frame support bars to the

mower's wheel hubs. The position of the mower places the bed knife pointing up.

The reel shaft requires an extension for a pulley. Drill a 3/8-in.-deep hole in 3/4-in. steel rod with a diameter to match that of the reel shaft. In our case, the diameter was 9/16 in. (see drawing on page 1753). Before welding this extension in place, mill a keyway to accept a 3/16-in. key in the pulley, or file a 3/32-in. flat to take a setscrew.

The sheet-metal work comes next. About as thick a sheet metal as could be readily worked and bent by hand was selected—24-ga. galvanized. All the bends can be made easily by clamping the work between two boards or between a board and a table edge. A 2 x 4 with a beveled edge of the required angle will handle other than right-angle bends.

Lay out the patterns on the sheet, as shown on page 1753, upper right, indicating the junction of lines with a punch mark. Then you can lay a straightedge across the marks and scribe the bending or cutting lines.

Note that some of the tabs are for riveting and

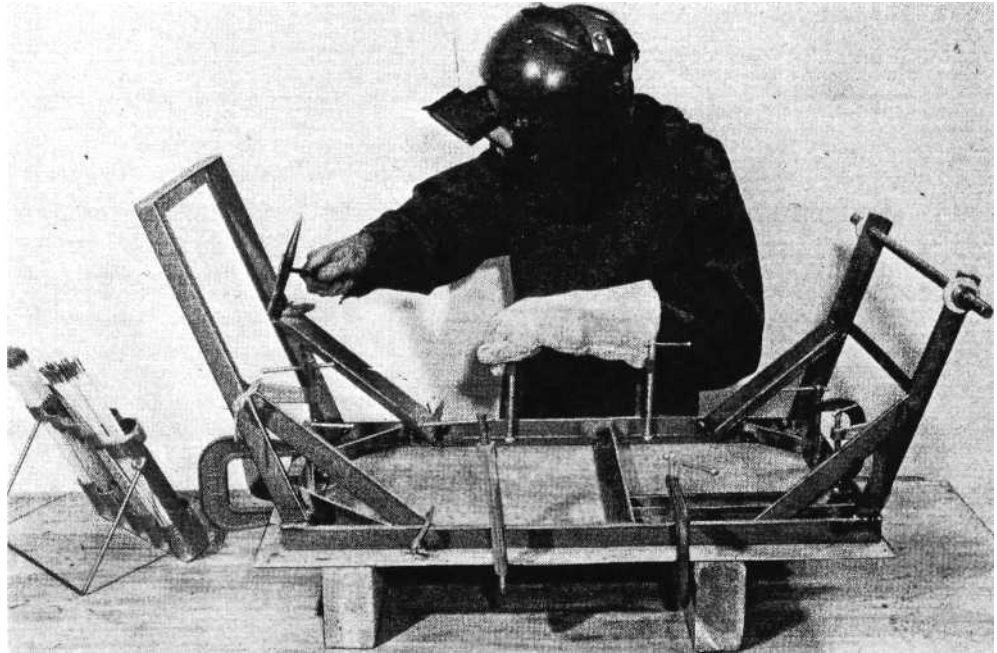

Sturdy carriage for the mulchmaker is completely welded: The board to which the frame is clamped to prevent warping is insulated from the table

some are hems to be folded flat to avoid sharp exposed edges. The sides of the hopper are canted 17 deg. and its backplate is inclined 45 deg. This assures an even feed and a wide enough opening.

Clamp the hood to the hood lugs with C-clamps, then punch and drill for the retaining bolts. Three 1/4-in. stove bolts on each side and, later, two through the backplate and the angle iron welded to the rear of the carriage, will be enough. When you have the hood bolted in place, cut the backplate to size and clamp it on. Drill No. 30 or 1/8-in. holes and secure it to the hood with short Pop rivets spaced 2 to 3 in. apart.

Transfer the pattern for the hopper to a sheet measuring 18-1/2 x 41 in., as shown on page 1754. You can work from the linear measurements without having to measure any angles. Install the three-sided part of the hopper carefully, making sure that it goes into place square and will clear the reel blades by about 1/4 in. Clamp it to the hood tabs; punch, drill and secure it with Pop rivets.

Cut the hopper backplate, bend the tabs, clamp it and rivet it into place.

The screen you install next holds back the material fed into the machine so it can be ground finer and provides a guard under the cutter blades. With a crayon, mark the uppermost reel blade in such a position as to indicate just where the rear edge of the hopper opening is. A properly adjusted bedknife will help insure this. Then remove the hood-and-hopper assembly.

Obtain a piece of 1/2-in. 18-ga. rolled ex-

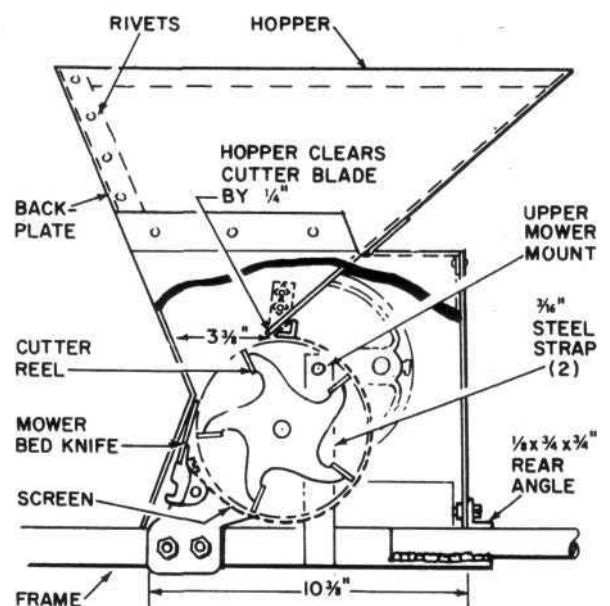

panded-metal screen (preferably heavier) 16 in. long and as wide as the mower bed-16-1/2 in. in this case. Pass it over the reel, under the mower bar and keep it close around and under the reel. Then bring it up inside and snug against the bed. Drill for 1/4 x 3/4-in. stove bolts at the ends of the bed where they will not interfere with the reel, and attach the screening.

make your own screen

If you have difficulty in finding expanded metal screen, make your own by drilling 1/4-in. to 3/8-in. holes in a screen pattern in 16-ga. or heavier sheet metal.

Now, cut away one side of the angle of 1/8 x 3/4 x 3/4-in. angle iron to fit between the wheel frames so that there is a tab 1-1/2 in. wider at each end. Bend these up at right angles and then place the angle iron on top of the screen, positioning its front edge just behind the crayon mark so the screen will not be in the way of the hopper opening. Finally, clamp it to the wheel-frame spokes.

Pull the screen up tight and bend it back over the angle iron. Reinstall the hopper to check for fit, then remove it again. Spot-weld the screen to the leading edge of the angle iron, using a 1/16-in. or 3/32-in. welding rod and the lowest possible amperage.

Finally, pass the screen-retaining wire around the mower bar, as indicated in the illustrations on page 1754. The ends of this wire, which should be stiff and heavy, are hooked through 1/4-in. holes drilled in the lower ends of the

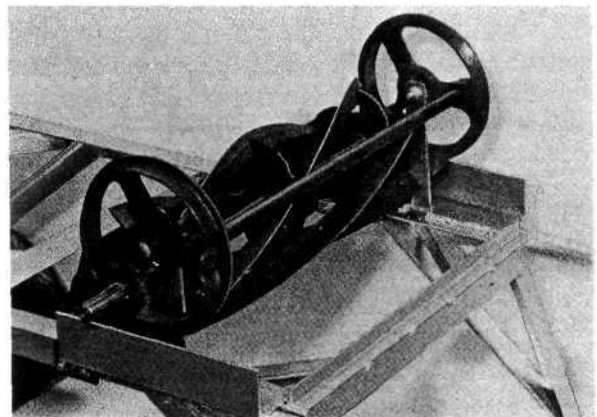
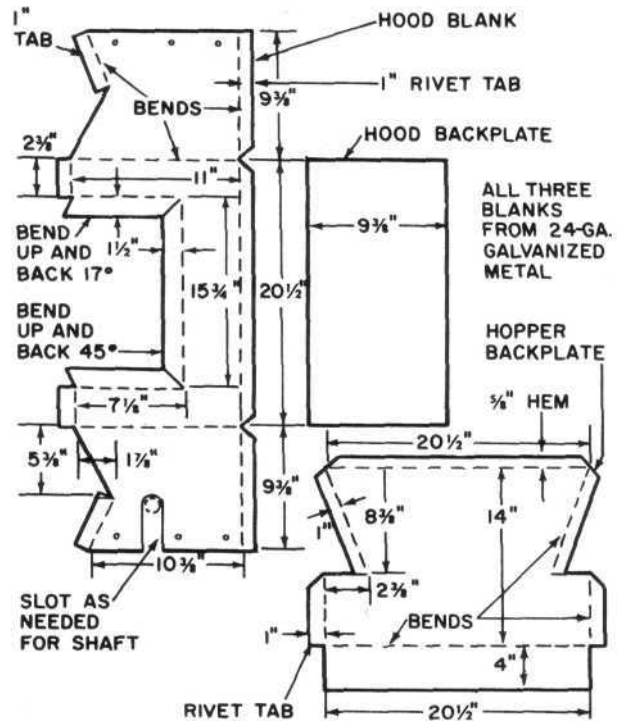

Mounted mower is attached on both sides through rear roller brackets to the carriage forward of the hood-support lugs and to welded-on bars bolted to and through the hubs of the mower's wheel frames

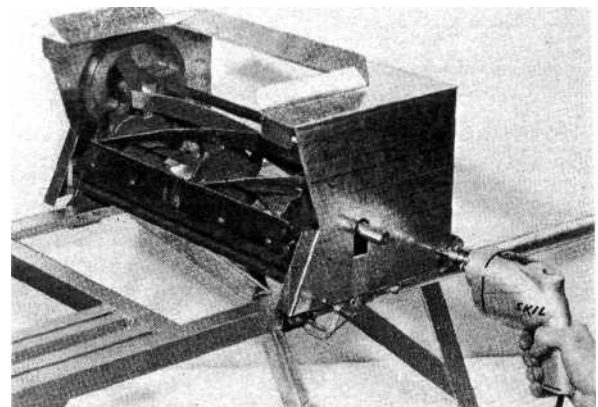
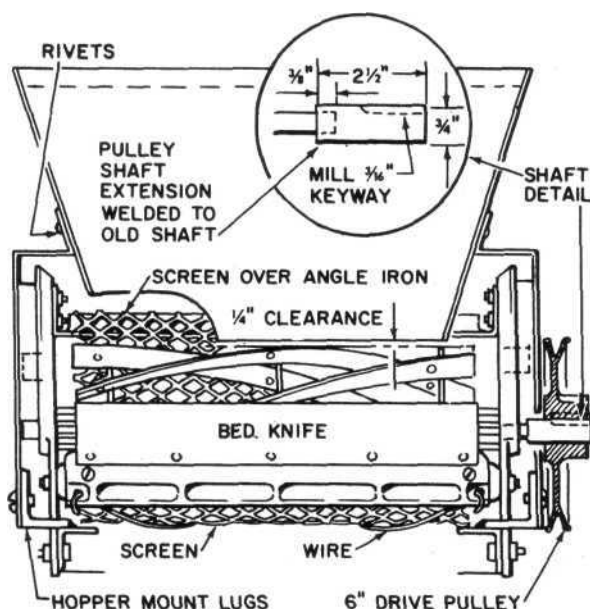

Mulcher hood is clamped in position and the holes are drilled through it and the welded hood lugs. Protruding from the side is not the reel shaft, but the extension to hold the pulley outside the hood

Completed hood-and-hopper assembly is riveted throughout. Note that the tabs of the hopper's upper edge are folded flat to eliminate the sharp edges

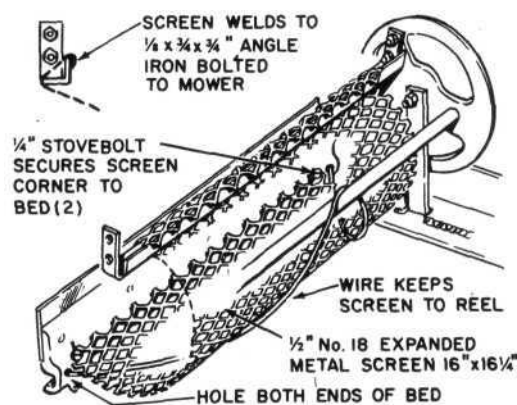
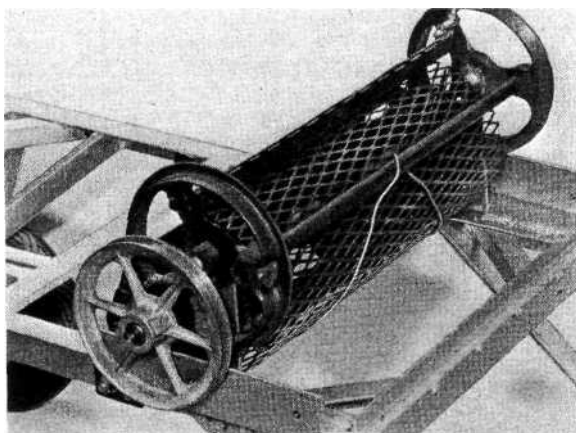

Screened reel produces a finer mulch and covers the whirling blades underneath. With the help of the retaining wire, the screen is a close fit; it serves as additional bed knives

mower bed. Draw the wire tight to take up slack and sag in the screen, but make sure the reel can just rotate. After adjusting the screen for proper fit, reclamp the angle iron to the spokes of the wheel frames. Drill through for two 1/4-in. bolts on each end.

Replace and bolt on the hood-hopper assembly; install the engine or motor, proper size pulleys for 1200 rpm and the belt. The job is done.

There's a right way and a wrong way to handle the mulchmaker. Feed material slowly. If the reel jams, the belt will slip, but shut off the engine before freeing it by pulling the reel pulley backwards. Don't decrease the reel pulley's size to increase the speed or you'll burn out your bearings. And if children are around, it would be wise to make a belt and pulley guard out of sheet metal.

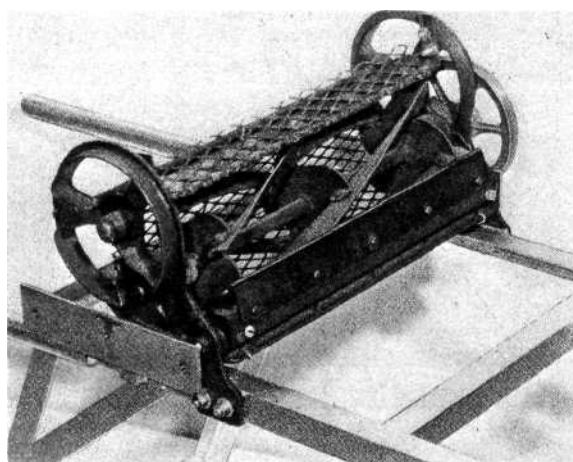

Front view of the screened reel shows the screen mounting bolts and looped ends of the retaining wire